



MATTHIESSEN BAG SPLITTER



Matthiessen Bag Splitter – SR_DA

Input-material:

- MSW up to 50 t/h
- Bio-Waste up to 50 t/h
- Co-Mingled up to 30 t/h
- Paper and Cardboard up to 30 t/h
- Recycle bags / Light material up to 17 t/h

Various Input Materials - Various Solutions

Working Widths: 60 inch / 69 inch / 79 inch
 Feeder: Heavy chain-belt conveyor / Z-Pan chain conveyor
 Bunker volumes: From 2 cu.yds to 78 cu. yds (From 1.5 m³ to 60m³)

Electrical power:

Rotor: 15 kW or 2 x 11kW gear motor
 Feeder: 0.75 – 1.5 kW gear motor, with frequency converter to control the speed of the conveyor

Around the world, Matthiessen Bagsplitters are working in the first phase of many recycling operations. These bag openers not only rip or split the bags, but also empty and meter the contents onto a conveyor. Materials are separated and prepared for downstream sorting and picking processes without being shredded into smaller pieces. Matthiessen Bagsplitters are also used as Bale Breaking or Dozing devices.

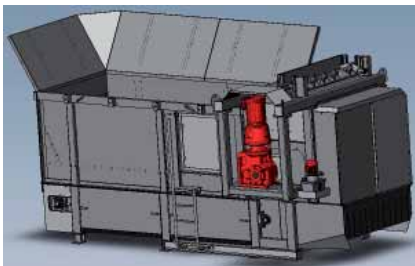

SRIIIplus K4 2 Segments

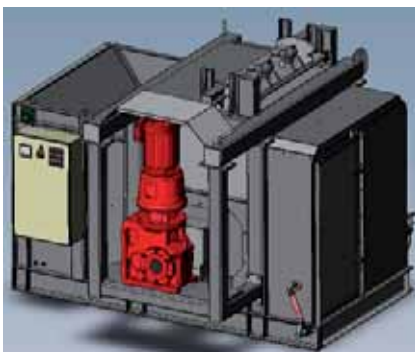

SRIIIDA K4 Hopper

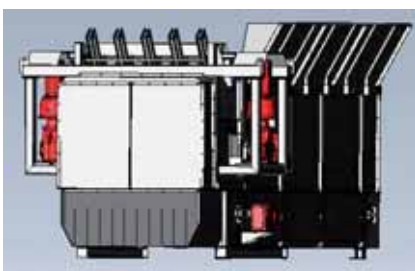

SRIVDA K4 3 Segments

Different models for different Throughputs

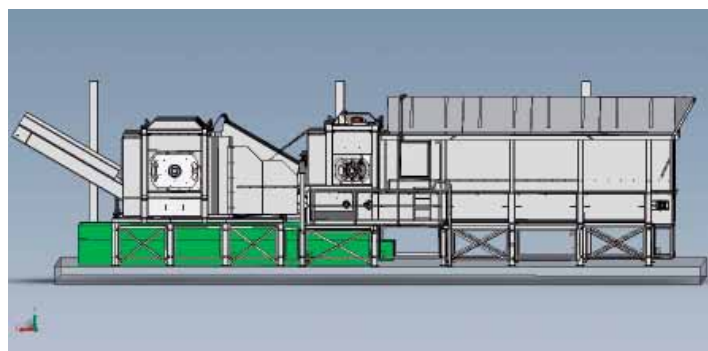
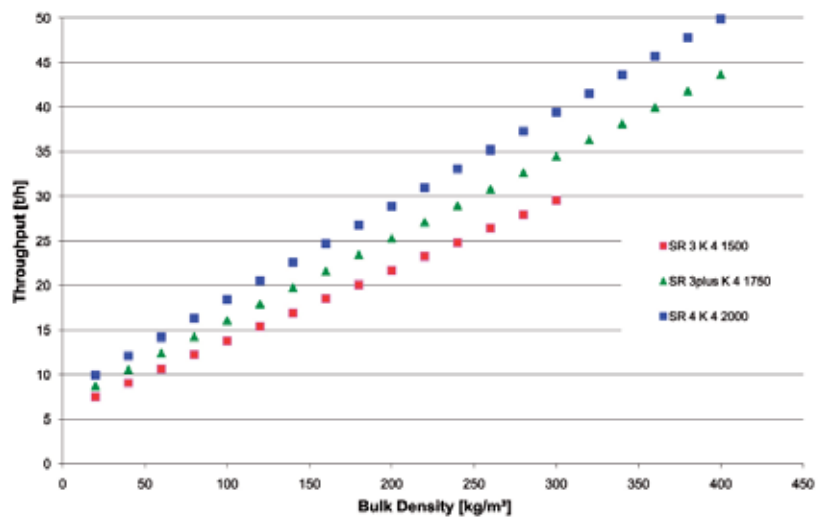

SRIIIDA K3 4Segments + Film Separator

Functionality “Matthiessen Bag Splitter”

Equipped with modern control systems, these machines improve productivity and product quality while also reducing energy costs in the plant.

Compared to a shredder, the bagsplitter consumes very little energy – as much as 90% less!

The Matthiessen bagsplitting / emptying / metering machine is designed to improve the recovery of recycle materials by opening bags and presenting the contents evenly on a conveyor for screening and optical or manual sorting or picking. Waste and/or recycling bags are dropped into the hopper by wheel loader or conveyor. A chain belt conveyor at the bottom of the hopper feeds the waste material in the direction of a rotating drum where bags are ripped opened.

The rotor drum has retractable ripping tines that catch and force the bags into the ripper comb located near the top of the drum. Rotor also available with fixed ripping tines.

After this ripping and emptying process the tines retract inside the rotating drum and release the opened bags and contents onto a waiting conveyor on the other side.

The separation between the ripper comb and the ripping tines is set so that the bags are pulled through a constricted space. The tines retract to minimize wrapping around the drum.

Bags are opened without compressing or shredding the contents or other loose material in the waste stream.

Over-size, bulky material such as lawn chairs, pails stacked inside each other, styrofoam parts, big packages or similar articles are reduced to a manageable size.

Smaller loose pieces may pass under the rotor and drop onto the process conveyor.

Although throughput of the bagsplitting / emptying / metering machine can be varied by adjusting the speed of the hopper drive belt, machine capacity is also very much dependent upon the density of the feedstock material. Subsequent screening and sorting steps will be accomplished with greater ease and accuracy.

The machine is equipped with automatic reverse operation (self cleaning) in case there is a heavy/bulky item that can't get over or under the rotor. When this happens, the rotor attempts three times to pass or rip the item and then stops to avoid damaging the unit.

The control panel indicates that there is a blockage and also notifies the operators when periodic maintenance is required.

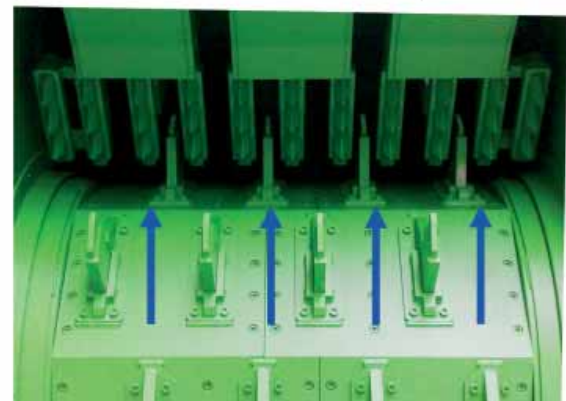
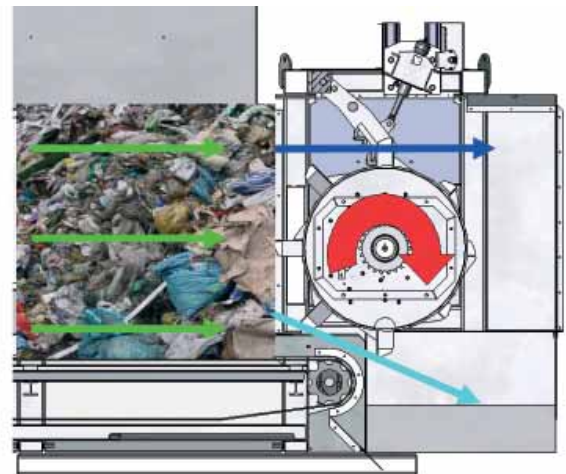
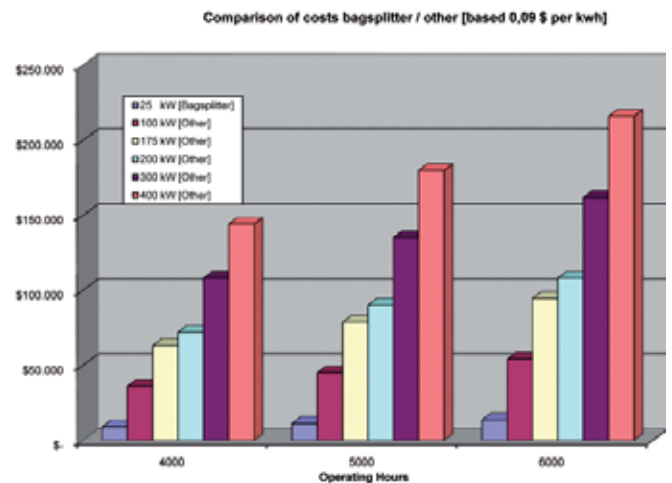



Matthiessen also manufactures:

- various types
- Film Separator
- Dozing and Metering Machines
- Walking Floors
- Chain Belt Conveyors
- Bale Breakers
- Roll Splitters
- Storage Systems for the printing industry

- ✓ Economic solution with various working widths
- ✓ Big Bunker volumes for extended reloading intervals
- ✓ Variety type of Ripping Combs available
- ✓ Heavy Chain Conveyor ensures constant feed
- ✓ High availability > 98 %
- ✓ Opening rate of the bags > 96 %
- ✓ Higher opening rates possible with special Ripping Knives
- ✓ No destruction of valuable recyclables
- ✓ Breaks-up and loosens compressed material
- ✓ Breaking of Bales also possible
- ✓ Low energy consumption
- ✓ Best preparation for picking and/or optical processes



Matthiessen Lagertechnik GmbH

Joh.-Hinr.-Fehrs-Straße 2 • 25361 Krempe Germany
 Tel. +49 4824 483 • Fax. +49 4824 2701
 info@matthiessen-technik.de
 www.bagsplitter.com